

Comparison of Vibration and Cae Techniques for the Condition Monitoring Of Rolling Element Bearings

R B Sharma¹, Yogesh Sharma²

¹Assistant Professor, Automobile Engineering Department, RJIT, BSF Academy, Tekanpur

²M Tech Scholar, Automobile Engineering Department, RJIT, BSF Academy, Tekanpur

ABSTRACT:

The hydrodynamic bearing is widely used in many industrial applications due to its characteristic of high load carrying capacity and suitability for high speed application with minimum power loss in friction. Any bearing defect (e.g. cracks, notch) occurring deteriorate the performance of the parts of any engine or machine. Detection of the defect at its budding stage and alerting/maintaining the user before it converts into a catastrophic failure is the aims of vibration monitoring technique or the present work.

In the present research work vibration analyses have been focused to detect bearing fault at the early stage. To accomplish above tasks a bearing test rig consisting bearing-crankshaft and coupling assembly & mode shape testing apparatus is developed to demonstrate the effectiveness of vibration analysis real time data & mode shapes related to bearing vibrations. Afterwards a bearing with a propagating crack is also examined for the mode shapes and its fundamental frequencies to deduce a relation for the condition monitoring of the system using FEM & CAE Technique on the platform of Ansys 14.0. A simulation for the study of bearing is carried out in the work and comparison is also made to validate the experiment based condition monitoring.

Keywords: Bearing, Bearing faults, fault diagnosis, vibration analysis, mode shapes, fundamental frequencies, CAE, Condition monitoring.

I. Introduction:

Failure of bearing is very common phenomena in the machine/Engine and after each and every failure, shut down of the machine takes place. It leads to time loss, labour loss, money loss, etc. failure of bearing occurs due to the production of unwanted cracks, unbalance forces, types of loading condition, improper lubrication, vibration etc. Condition monitoring of bearings in rotating machinery using vibration analysis is a very useful method. It offers the advantages of reducing down time and improving maintenance efficiency and increase the availability of machine so that production may also be increased.

The term “rolling bearing” includes all forms of roller and ball bearing which permit rotary motion of a shaft. Rolling bearings are high precision, low cost but commonly used in all kinds of rotary machine. The hydrodynamic journal bearing with its geometry is shown in following figure 1 this shows both circumferential as well as axial pressure distribution in hydrodynamic journal bearing. This figure shows all geometrical parameters of hydrodynamic journal bearing such as radius of journal, radius of bush, minimum oil film thickness, attitude angle etc.

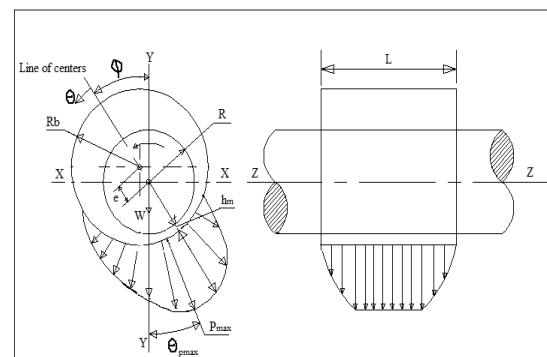

Fig 1: Hydrodynamic journal bearing geometry

Bearing faults which can be detected with vibration analysis: Excessive loads, Overheating, True brine ling, False brine ling, Normal fatigue failure, Reverse loading, Contamination, Lubricant failure, Corrosion, Misaligned bearings, Loose fits, Tight fits.

Condition monitoring involves the continuous or periodic assessment of the condition of a plant or a machinery component while it is running. Basically condition monitoring is the process of monitoring some parameters from the machinery, such that a significant change in the parameter can give information about the health of the machinery. It involves the continuous or periodic assessment of the condition of a plant or a machinery component while it is running. To

identify the most probable faults leading to failure, many methods are used for data collection, including vibration monitoring, thermal imaging, oil particle analysis, etc. Then these data are processed utilizing methods like spectral analysis, wavelet analysis, wavelet transform, short term Fourier transform, Gabor Expansion, Wigner-Ville distribution (WVD), cepstrum, bispectrum, correlation method, high resolution spectral analysis, waveform analysis and others. The most common technique of detecting fault is the time-frequency analysis technique.

The concept of FEM states an equation for the basic formulation of the structures/machines into the matrix format to make the computation easier. These matrixes are of stiffness, nodal displacements and force matrixes.

$$[K] [Q] = [F]$$

Where, [K] = element stiffness matrix; [Q] = nodal displacement matrix; [F] = force matrix;

These expressions are generally used for every case of structural studies and analysis but here we are considering a dynamic analysis for which the dynamic parameters will come into picture for the evaluation. If a solid body such as an engineering structure is deformed elastically and suddenly released, it tends to vibrate about the equilibrium position. This periodic motion due to restoring strain energy is called free vibrations. The undamped free vibration model of a structure gives significant information about its dynamic behaviour. Every system has its own mass, there for it can also be reduced to general form of the spring mass system as shown in figure 2.

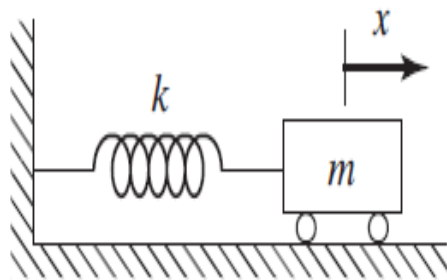

Figure 2, spring mass system

The general equation for the dynamic analysis of any system is given by

$$M\ddot{x} + c\dot{x} + kx = 0$$

Where, m = mass of the system; c = damping provided by the system and k = material stiffness of the system, \dot{x} : represents the displacement and \ddot{x} : acceleration of the system

Now if the force F is applied at the end terminal of the mass m then the above expression can be modified as

$$M\ddot{x} + c\dot{x} + kx = F$$

Now for the FEM analysis the above equation is converted into the matrix format for the simulation and evaluation of Eigen values and Eigen vectors. Eigen values are known as the natural frequencies and the Eigen vectors are the natural mode shapes of the object. The matrix form of the equation is shown below

$$[m][\ddot{x}] + [k][x] = F$$

Where, [m] is the mass matrix and [k] is the stiffness matrix and \ddot{x} and x are the vectors representing accelerations and displacements

II. Problem Formulation:

In the present work, the behaviour of the bearing coupled with crankshaft of Herohonda 100 CC has been analysed under different condition for strength & rigidity simultaneously and proper function of engine. The first case stated as the performance of the bearing after a run of 15000 kilometres without any crack propagation or any notch formation. And the second case for a same bearing stated after a run of 22000 kms, when a notch type crack detected after intensive examination due to which excessive noise and vibration has been created. The fundamental mode shapes and the fundamental frequency has to be evaluated for the vibration monitoring of the bearing for both of the cases by experimentally as well as CAE methodology.

Research Aim:

The aim of this research is to develop more accurate and sensitive condition monitoring, fault detection and diagnosis tools that can be used for fault detection of bearing of rotary shafts. This work focuses the different approaches for condition monitoring, simulation and practical outcome have to be analysed and to compare them for the bearing. This work also targets about the relationships of the mode shapes and the fundamental frequency of the bearing at which resonance may appear. This work also focuses on the validation of the experimental setup to the simulation results using CAE methodology.

III. Methodology & Experimental Work:

(a) Experimental Setup & Methodology for the Investigation

The experimental work comprises of tests under the actual working condition of the bearing of Herohonda 100 CC, when it is modelled in the Ansys the same boundary conditions and constraints is applied.

The block diagram of the experimental setup is shown in figure 3 for monitoring the vibrations of the bearing.

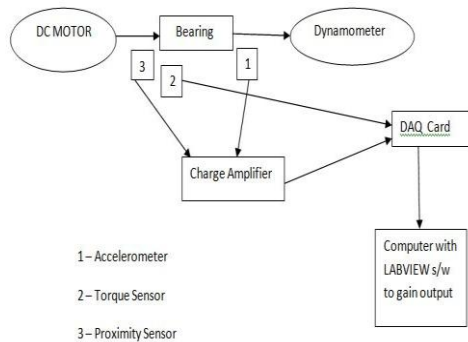

In the above block diagram, the bearing is mounted in between the DC motor and Eddy Current Dynamometer. The power or the motion is supplied by the DC motor to the bearing via couplings with crankshaft. The DC motor is fitted with the blower to cool the motor running for a long time under the specified engine load. The Eddy current dynamometer is used to absorb/nullify the effect the reverse current generally known as eddy current. The instruments used for the experiments are tabulated in Table: 1

Figure 3: Block diagram of experimental test rig

S. No.	Assembled Components	Data Measuring Instruments	
1	Bearing	8	Accelerometer
2	DC shunt motor	9	Charge Amplifier
3	DC shunt motor blower	10	Proximity sensor
4	Tacho Generator	11	DAQ card
5	Eddy current dynamometer	12	LabVIEW
6	Coupling	13	Torque sensor
7	Base plate		

Table 1: Components & Instruments used

The bearing which has been used here has already completed a run of 15000 kms, which is of Herohonda 100 CC and shown in figure 4. The dimensions of the bearing have been noted down. The bearing has been then monitored for its

vibration behaviour with experimental set up and the data have been recorded and its simulation is also carried in Ansys 14.0 after the modelling of bearing in Pro/E wildfire 4.0 software.



Figure 4: Bearing of Engine of Herohonda 100 cc

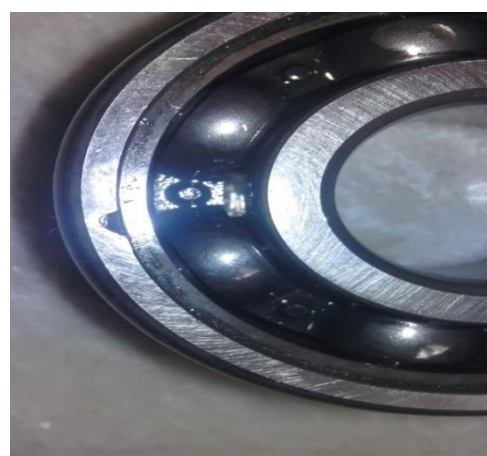

Figure 5: Notch type crack on Bearing

Again after an interval of 7000 kms i.e. on 22000 kms, it is found that the engine was producing noise and vibration and the fuel

economy was also low. So it has been examined, and a propagating notch type crack has been found on the bearing as shown in the figure 5, so it has been monitored under the experimental investigation and the mode shape testing apparatus and its simulation is also carried in Ansys 14.0 after

the modelling of bearing in Pro/E wildfire 4.0 software.

(b) Experimental investigation for the bearing without defect:

(i) Condition Monitoring on the basis of Experimental Vibration Analysis:

A machine in standard condition has a certain vibration signature. Fault development changes that signature in a way that can be related to the fault. When vibration features of the components are obtained, its health condition can be determined by comparing these patterns with those corresponding to its normal and failure conditions. Diagnosing a bearing system by examining the vibration signals is the most commonly used method for detecting bearing failures. The principal vibration frequencies in the vibration signal are:

- The primary rotation frequency of bearing and its harmonics.
- The load frequency (bearing under the applied engine load) and its harmonics.
- Sidebands of the bearing harmonics.

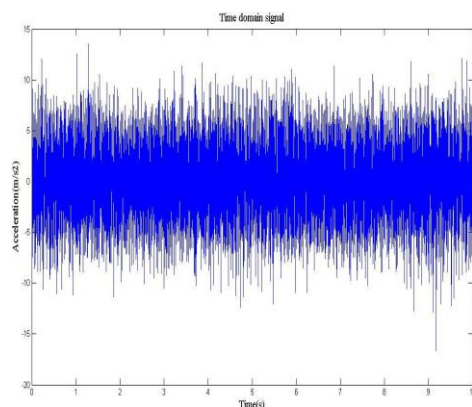

Figure 6: Time domain without (TSA) signal plot at 3500 rpm with loading

Time domain signal of bearing running at 3500 rpm is shown in Figure 6. To extract useful information, the bearing has been placed on the modal analysis apparatus and experimental set up. Mode shapes have been obtained from the experimental modal analysis. Frequency domain signal and other relevant parameters have been collected from the labview software & FFT which is the part of experimental setup. In the present study time synchronous averaged signal (TSA) technique has been used.

(ii) Condition Monitoring on the basis of CAE methodology using Ansys:

A numerical simulation of the bearing is performed using Ansys, and practical investigations are

carried out as well to verify the proposed measurement approach. Simulation and experimental results are used to assess the applicability of the approach for condition monitoring of bearing.

The element type used for the analysis of bearing in Ansys is brick 8node solid 185 element. SOLID185 is a structural solid which is suitable for modeling general 3-D solid structures. It allows for prism, tetrahedral, and pyramid degenerations when used in irregular regions. Various element technologies such as B-bar, uniformly reduced integration, and enhanced strains are supported. SOLID185 is used for 3-D modeling of solid structures. It is defined by eight nodes having three degrees of freedom at each node: translations in the nodal x, y, and z directions. The element has plasticity, hyperelasticity, stress stiffening, creep, large deflection, and large strain capabilities. It also has mixed formulation capability for simulating deformations of nearly incompressible elastoplastic materials, and fully incompressible hyperelastic materials.

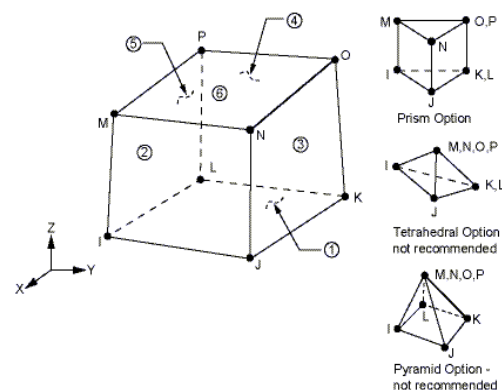
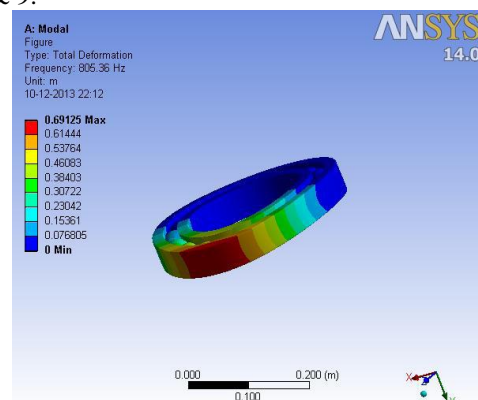

Figure 7: Solid185 Homogeneous Structural Solid Geometry

The detail about the analysis of the bearing and its mode shapes is shown in the figures 8 & 9:



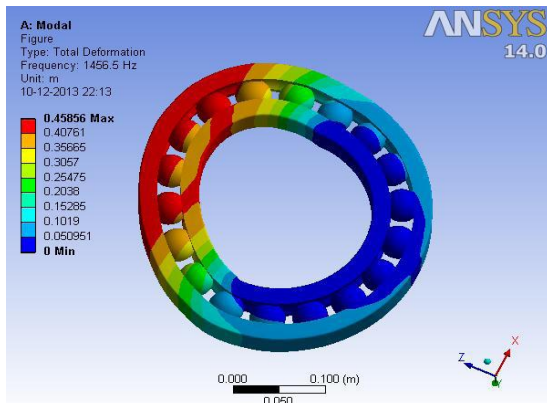

Figure8: First mode shape of bearing from Ansys
Figure 9: Second mode shape of bearing from Ansys

Following points may be noted from above mentioned Figures of mode shapes:

- The primary rotational frequency of bearing is 805.36.0 Hz.
- The initial mode shapes obtained from the oscilloscope are of bending types.
- The mode shapes also provides the deformation values for the specified values of frequency for the respective mode shape.
- In the present study Block Lanczos technique for the modal analysis in Ansys has been used.

(c) Experimental investigation for the bearing with notch type crack/defect:

(i) Condition Monitoring on the basis of Experimental Vibration Analysis:

After an intermediate run of 7000 Kms i.e. on 22000 kms, we have inspected the bearing thoroughly and as found a crack on the outer race of the bearing as shown in the figure 5, which may be aroused due to the following noticeable points:

- Misalignment of the bearing, (2) Excessive vertical and side thrust, (3) Dust dirt or debris in oil
- Excessive wear & tear due to continuously running of engine, (5) Due to stress on outer race of bearing.

The experimental investigation for the mode shapes and the critical frequencies of the cracked bearing have been obtained from the experimental test rig setup and the mode shapes experimental step up. The bearing has been remounted on the experimental test rig and again rotated at the 3500 rpm which the most commonly used rpm for the engine to accelerate and to hold the vehicle in idle running condition. Hence this is the rpm of the bearing at which the high loads are applied to the bearing. The mode shapes are then plotted from the mode shape experimental setup via oscilloscope.

(ii) Condition Monitoring on the basis of CAE methodology using Ansys:

For the simulation of the cracked bearing using CAE methodology, the dimensions of notch type crack of the bearing are noted down and using the same dimensions crack is impinged in the model in the Pro/E wildfire 4.0 approximately. This model is consider as the cracked bearing for the further analysis of vibration based condition monitoring.

Dimensions of crack of bearing:

Profile of crack	Approximately triangular type
Length of crack on each side	12 mm (approx)
Length of crack on base side	14 mm (approx)
Depth of crack	27 mm (approx)

Table 2: Details of notch type of crack of bearing

The dimensions of the crack have been measured with the profile projector and were calibrated by CMM (co-ordinate measuring machine) by the workshop manager. The model is evaluated for the FEM analysis under the modal analysis head, to know the resulting fundamental frequency of the cracked crankshaft using ANSYS 14.0.

The Ansys based detail study of mode shape analysis of cracked bearing is shown in the figures 11 & 12:

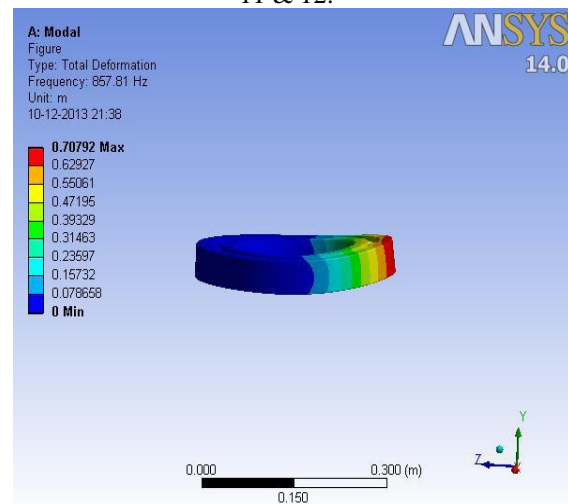

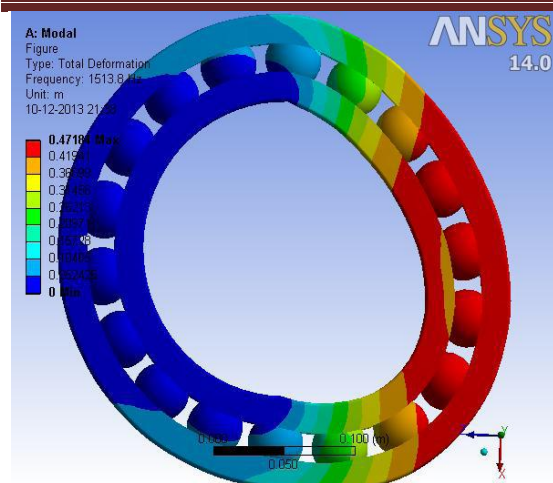

Figure 11: First mode shape of cracked bearing from Ansys Figure 12: Second mode shape of cracked bearing from Ansys

IV. Result & Discussion:

The bearing which has been analyzed here was real problem of M/s Bhoomi Auto Engineering & Service Centre, Dabra, Gwalior. The bearing has been then examined for its condition experimentally and by simulation also. The experimental values of the frequency at which bearing was vibrating are 778.4 Hz, 1402.7 Hz, for respective mode shapes. Now utilizing these values of frequencies mode shapes of bearing were noted. At this stage the bearing has already travelled a distance of 15000 Kms. In the CAE methodology, a simulation has been also performed, for which the model is developed keeping the scale factor of 1:1 with suitable dimensions. Then a modal analysis of this model of bearing has been executed using Ansys 14.0. The result derived from this work is stated in table 3 which is validated by experimental values.

In the second case, the bearing has been tested after a travel of 22000 Kms, during which a notch type crack was detected at the outer race of bearing. The bearing has been then examined for its condition experimentally and by simulation also. The experimental values of the frequency at which bearing was vibrating are 821.9 Hz, 1458.5 Hz, for respective mode shapes. Now utilizing these values of frequencies mode shapes of bearing were noted. For the implementation of CAE technique, the dimensions and the profile were noted approximately for the model development of the cracked bearing. This model of cracked bearing has been developed in Pro/E wildfire 4.0 and then after it has been again evaluated in the Ansys 14.0 for the modal analysis to know the frequency and the mode shapes. The result generated from the report is depicted in table 3 which is validated by experimental values.

Now, a comparative table has been drawn to make the results very clear as table 3. The comparison is drawn in between the experimental investigation and the modal analysis using CAE methodology of the bearing with & without crack. The results obtained from the simulation are approximately validates by the experimental ones.

F1 (Hz)	F2 (Hz)	Natural Frequency	
778.4	1402.7	Experimental Analysis	Bearing without crack
805.36	1456.5	CAE Based modal Analysis	
821.9	1458.5	Experimental Analysis	Bearing with crack
857.81	1513.8	CAE Based modal Analysis	

Table 3: Comparative results table

V. Conclusion:

The bearing used for this work is of single cylinder SI engine of Hero Honda 100 cc. The material of bearing was stainless steel. It was found that the bearing was vibrating with a high magnitude in 15000 Kms and then after more high magnitude in 22000 kms, so it was a real problem to be evaluated.

The presented work clearly shows as conclusion that if any defect occurs in the bearing or any rotor or any machine component, the range of frequencies is increased so that dynamic behavior of bearing has been quite different in respect of vibration. Hence, with the help of this work, investigation of the behaviour of bearing after locating a defect is analyzed as vibration so that we can put the attention for the safety features as well as design features of the bearing and selection of material of bearing also. Finally, this study is also useful to provide the safety features against the catastrophic failures of bearing because the analysis of condition of bearing may be evaluated with the help of CAE based modal analysis using creating/modeling the same model of bearing with defect as comparison with the size & nature of defect of bearing in practical real ground.

Vibration based condition monitoring has been done on the bearing by two different approaches viz. experimental vibration investigation & CAE based modal analysis and the simulation based modal analysis using the Ansys Workbench Platform. The experimental and the simulation results were quite very closer to each other. Hence simulation based condition monitoring can be a next step in the fault diagnosis of the bearing. in order to minimize bearing

downtime and to avoid performance degradation, a practical and tough monitoring system is needed to provide early warnings of malfunction or possible damage, which may lead to sudden or even devastating failures and both approaches mentioned in this work is useful for the same.

References:

- [1] A comparison of some vibration parameters for the condition monitoring of rolling element bearings Measurement, Volume 12, Issue 3, January 1994, Pages 285-289 (N. Tandon)
- [2] Statistical analysis of sound and vibration signals for monitoring rolling element bearing condition Applied Acoustics, Volume 53, Issues 1–3, January–March 1998, Pages 211-226 (R.B.W. Heng, M.J.M. Nor)
- [3] Diagnostics of rolling-element bearing condition by means of vibration monitoring under operating conditions Measurement, Volume 2, Issue 2, April–June 1984, Pages 58-62 (A. Sturm, Dipl-Ing D. Kinsky)
- [4] A comparative experimental study on the use of acoustic emission and vibration analysis for bearing defect identification and estimation of defect size Mechanical Systems and Signal Processing, Volume 20, Issue 7, October 2006, Pages 1537-1571, Abdullah M. Al-Ghamd, David Mba (Abdullah M. Al-Ghamd, David Mba)
- [5] Damage Monitoring of Ball Bearing CIRP Annals – Manufacturing Technology, Volume 55, Issue 1, 2006, Pages 427-430 T. Hoshi
- [6] A fault diagnosis approach for roller bearing based on VPMCD under variable speed condition Measurement, Volume 46, Issue 8, October 2013, Pages 2306-2312 Yu Yang, Huanhuan Wang, Junsheng Cheng, Kang Zhang
- [7] A classifier fusion system for bearing fault diagnosis Expert Systems with Applications, Volume 40, Issue 17, 1 December 2013, Pages 6788-6797 Luana Batista, Bechir Badri, Robert Sabourin, Marc Thomas}
- [8] Bearing and Gear Fault Diagnosis Using Adaptive Wavelet Transform of Vibration Signals Procedia Engineering, Volume 50, 2012, Pages 265-274 D.P. Jena, S.N. Panigrahi
- [9] Vibration analysis of rolling element bearings with various defects under the action of an unbalanced force Mechanical Systems and Signal Processing, Volume 20, Issue 8, November 2006, Pages 1967-1991 Zeki Kiral, Hira Karagülle
- [10] Simulation and analysis of vibration signals generated by rolling element bearing with defects Tribology International, Volume 36, Issue 9, September 2003, Pages 667-678 Zeki Kiral, Hira Karagülle
- [11] A review of vibration and acoustic measurement methods for the detection of defects in rolling element bearings Tribology International, Volume 32, Issue 8, August 1999, Pages 469-480 N Tandon, A Choudhury.